

Norwolf Tool Works presents the

STUDMATE™

U.S. AND INTERNATIONAL PATENTS APPROVED AND PENDING

This clever tool threads onto your frozen studs in seconds like a normal hex nut. After simply tightening the six cap screws securely, the **STUDMATE** loosens the frozen stud with any standard socket or wrench.

Unlike conventional stud removers that are not only costly, but bulky and require special removal tools, the Studmate hex style stud removers are the same dimension as the nut you removed...therefore, it not only fits where your nut fits, it requires the same tools you already have!

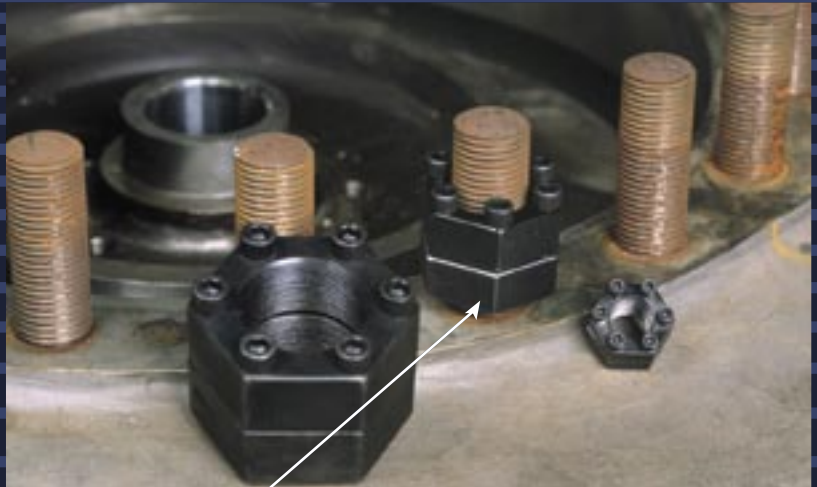

Threads on close to base reducing side load when removing stud.

All common bolting tools can be used with **STUDMATE**.



Norwolf Set 1 in custom fitted box

Threads

Cap Screws

Standard Heavy Hex Dimensions

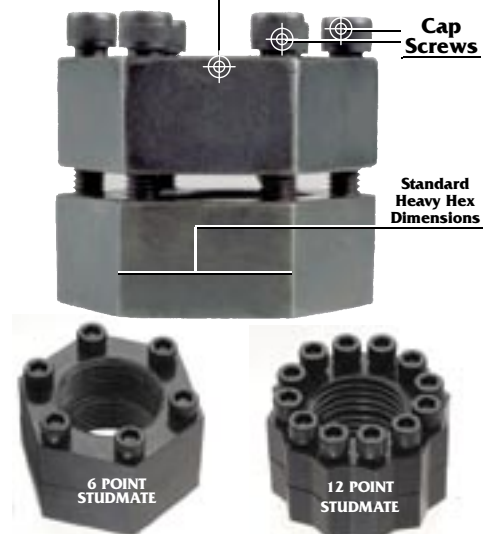

For extra heavy duty use, we strongly recommend the Norwolf Studmate 12pt. design.

GROUP 1

PART NO.	THREAD	HEX SIZE
SM-50-13	1/2"-13	7/8
SM-50-20	1/2"-20	7/8
SM-56-12	9/16"-12	15/16
SM-56-18	9/16"-18	15/16
SM-62-11	5/8"-11	1-1/16
SM-62-18	5/8"-18	1-1/16
SM-75-10	3/4"-10	1-1/4
SM-75-16	3/4"-16	1-1/4
SM-87-9	7/8"-9	1-7/16
SM-87-14	7/8"-14	1-7/16
SM-10-12	1"-12	1-5/8
SM-10-14	1"-14	1-5/8

AVAILABLE IN BOTH 6 AND 12 POINTS

Listed part numbers denote 6 point Studmates. Add -12PT to Part No. for 12 point Studmate.

GROUP 2

PART NO.	THREAD	HEX SIZE
SM-112-7	1-1/8"-7	1-13/16
SM-112-8	1-1/8"-8	1-13/16
SM-112-12	1-1/8"-12	1-13/16
SM-125-7	1-1/4"-7	2
SM-125-8	1-1/4"-8	2
SM-125-12	1-1/4"-12	2
SM-137-6	1-3/8"-6	2-3/16
SM-137-8	1-3/8"-8	2-3/16
SM-137-12	1-3/8"-12	2-3/16
SM-150-6	1-1/2"-6	2-3/8
SM-150-8	1-1/2"-8	2-3/8
SM-150-12	1-1/2"-12	2-3/8
SM-175-5	1-3/4"-5	2-3/4
SM-175-8	1-3/4"-8	2-3/4
SM-175-12	1-3/4"-12	2-3/4
SM-20-450	2"- 4-1/2	3-1/8
SM-20-8	2"-8	3-1/8
SM-20-12	2"-12	3-1/8

GROUP 3

PART NO.	THREAD	HEX SIZE
SM-10-8	1"-8	1-5/8
SM-112-8	1-1/8"-8	1-13/16
SM-125-8	1-1/4"-8	2
SM-137-8	1-3/8"-8	2-3/16
SM-150-8	1-1/2"-8	2-3/8
SM-162-8	1-5/8"-8	2-9/16
SM-175-8	1-3/4"-8	2-3/4
SM-187-8	1-7/8"-8	2-15/16
SM-20-8	2"-8	3-1/8
SM-225-8	2-1/4"-8	3-1/2
SM-250-8	2-1/2"-8	3-7/8
SM-275-8	2-3/4"-8	4-1/4
SM-30-8	3"-8	4-5/8
SM-325-8	3-1/4"-8	5
SM-350-8	3-1/2"-8	5-3/8
SM-375-8	3-3/4"-8	5-3/4
SM-40-8	4"-8	6-1/8

The Norwolf STUDMATE is also available in metric sizes.

SET 1 SM-S50-10

12-Piece set in fitted case consisting of sizes 1/2" - 1" coarse and fine thread from Group 1.

SET 2 SM-S112-200

18-Piece set in fitted case consisting of sizes 1-1/8" - 2" coarse and fine thread from Group 2.

SET 3 SM-SP10-40

17 Piece set for power plants and refineries consisting of 8 TPI nuts (1"4") from Group 3.

SET 4 SM-MS-50-20

Master set groups 1 and 2 in fitted case.

SET 5 SM-MS-5-20

Master set groups 1 and 3 in fitted case.