

**MCH**

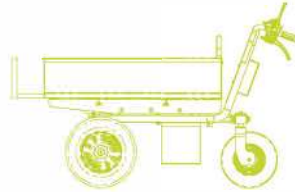
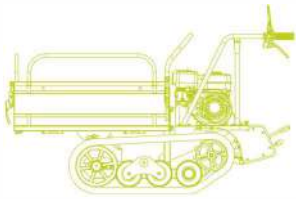

# Catalog

# 2020

**MCH**

[www.mchworld.com](http://www.mchworld.com)





M500H MCH

M500H MCH

M350 MCH

W350e MCH

MCH





# Contents

1 - 4

## M SERIE

Powered track Barrow

M350

M500

M500H

5 - 8

## M SERIE e

The strength of the M Series with the advantages of electric

M350e

M500e

M500He

9 - 10

## W SERIE e

A range of 100% electric wheeled machines

W350e

### UPCOMING SOON

W150e

W500e





# M SERIE



**MCH**





## MINITRANSPORTERS

# M SERIE

### VERSATILITY AT YOUR SERVICE

The M350 and M500 are versatile machines designed to facilitate the transport of loads or bulky objects. From 350 to 500kg depending on the model, the M series transporters simplify transport for you, whatever your specialty. Construction, Agriculture, Maintenance of green spaces... The M350 and M500 mini dumpers are real daily allies. Sand, Wood, Rubble... transport your load, limit your efforts and focus your energy on more important tasks!

Their compact size of 66cm wide allows them to go through doors and facilitates their transport by truck or trailer. Equipped with a bucket with a volume of 2m<sup>3</sup> (approximately) these carriers will be one of your toughest assistants to transport your load. Their extendable drop size allow you to adapt the bucket to your load. The assistance of the gas spring will facilitate your effort during the unloading of the bucket.

Boost your productivity with the hydraulic tipping of the M500H model.

## M 350

## M 500

## M 500H



# M350

# M500

## ENGINE

## ENGINE

ENGINE BRAND



**GX160**  
**163 CM3 / 3,6KW**  
**3600 TR/MIN**

**LS208**  
**208 CM3 / 4,1KW**  
**3600 TR/MIN**

ENGINE BRAND



**GX200**  
**196 CM3 / 4,1KW**  
**3600 TR/MIN**

**LS208**  
**208 CM3 / 4,1KW**  
**3600 TR/MIN**

ENGINE TYPE

**4 STROKES, MONOCYLINDER OHV**

ENGINE TYPE

**4 STROKES, MONOCYLINDER OHV**

GEARBOX

**6 FW / 2 BW**

GEARBOX

**6 FW / 2 BW**

STARTING SYSTEM

**MANUAL**  
**OR ELECTRIC**  
**IN OPTION**

STARTING SYSTEM

**MANUAL**  
**OR ELECTRIC**  
**IN OPTION**

## CAPACITY

## CAPACITY

MAX PAYLOAD (FLAT/SLOPE)

**350 KG / 250 KG**

MAX PAYLOAD (FLAT/SLOPE)

**500 KG / 350 KG**

MAX GREADABILITY

**35%**

MAX GREADABILITY

**35%**

NET WEIGHT

**170 KG**

NET WEIGHT

**195 KG**

## ADDITIONAL INFO.

## ADDITIONAL INFO.

OVERALL DIMENSIONS

**169X63X99 CM**

OVERALL DIMENSIONS

**196X63X99 CM**

TIPPER DIMENSIONS

**82X54X31,4 CM**

TIPPER DIMENSIONS

**109X54X31,4 CM**

TIPPING SYSTEM

**GAS PISTON**

TIPPING SYSTEM

**GAS PISTON**

RUBBER TRACK SIZE

**180X60X37 CM**

RUBBER TRACK SIZE

**180X60X42 CM**



# M500H

## DROP SIDES

### ENGINE

ENGINE BRAND



**GX200**  
**196 CM3 / 4,1KW**  
**3600 TR/MIN**



**LS208**  
**208 CM3 / 4,1KW**  
**3600 TR/MIN**

ENGINE TYPE

**4 STROKES, MONOCYLINDER OHV**

GEARBOX

**6 FW / 2 BW**

STARTING SYSTEM

**MANUAL**  
**OR ELECTRIC**

**IN OPTION**

### CAPACITY

MAX PAYLOAD (FLAT/SLOPE)

**500 KG / 350 KG**

MAX GREADABILITY

**35%**

NET WEIGHT

**195 KG**

### ADDITIONAL INFO.

OVERALL DIMENSIONS

**196X63X99 CM**

TIPPER DIMENSIONS

**109X54X31,4 CM**

TIPPING SYSTEM

**HYDRAULIC**

HYDRAULIC SYSTEM

**PRESSURE - 160 BAR**  
**MAX PUMPFLOW - 9,6 L/MIN**  
**DOUBLE EFFECT HYDRAULIC CYLINDER**

RUBBER TRACK SIZE

**180X60X42 CM**

### ENGINE

ENGINE BRAND



**GX200**  
**196 CM3 / 4,1KW**  
**3600 TR/MIN**



**LS208**  
**208 CM3 / 4,1KW**  
**3600 TR/MIN**

ENGINE TYPE

**4 STROKES, MONOCYLINDER OHV**

GEARBOX

**6 FW / 2 BW**

STARTING SYSTEM

**MANUAL**  
**OR ELECTRIC**

**IN OPTION**

### CAPACITY

MAX PAYLOAD (FLAT/SLOPE)

**500 KG / 350 KG**

MAX GREADABILITY

**35%**

NET WEIGHT

**195 KG**

### ADDITIONAL INFO.

OVERALL DIMENSIONS

**183X63X110 CM**

TIPPER DIMENSIONS

**103X73X49 CM**

TIPPING SYSTEM

**HYDRAULIC**

HYDRAULIC SYSTEM

**PRESSURE - 160 BAR**  
**MAX PUMPFLOW - 9,6 L/MIN**  
**DOUBLE EFFECT HYDRAULIC CYLINDER**

RUBBER TRACK SIZE

**180X60X42 CM**



# M SERIE



**MCH**





# ELECTRIC POWER ENGINE



## VERSATILE AND FULL OF ENERGY

Little sister of the M serie, the Me serie consists of a range of machines with 100% electric motors, which are respectful of the environment.

Say goodbye to noise pollution: silent, these machines will be the ideal partner for all your indoor and outdoor work and even in the presence of animals or neighbours. You will also increase your working comfort and benefit from increased productivity even with prolonged use.

The electric starter allows you to start easily whatever the weather conditions. Your engine then delivers the maximum of its power instantly to allow you to take full advantage of the abilities of your machine.

**M 350**  
**M 500**  
**M 500H**







# M350e

# M500e

## ENGINE

### ENGINE REFERENCE

 **MCH MOTORS**  
**BLDC «HIGH TORQUE» SERVOMOTOR**

### ENGINE TYPE

**ELECTRIC**  
**WITH OVERLOAD PROTECTION**  
**POWER (HP/KW) : 1,36/1,0**  
**LITHIUM BATTERY : 48V 60AH**

### GEARBOX

**6 FW / 2 BW**

### STARTING SYSTEM AND TECHNOLOGY

**ELECTRIC**  
**S3 (SOFT START AND STOP FUNCTION)**

ALLOWS YOU A SMOOTH ACCELERATION AND STOP AND AVOIDS BUMPS.

## CAPACITY

### MAX PAYLOAD (FLAT/SLOPE)

**350 KG / 250 KG**

### MAX GREADABILITY

**35%**

### NET WEIGHT

**170 KG**

## ADDITIONAL INFO.

### OVERALL DIMENSIONS

**163X66X110 CM**

### TIPPER DIMENSIONS

**87X54X26,5 CM**

### TIPPING SYSTEM

**MANUAL WITH GAS PISTON**

### RUBBER TRACK SIZE

**180X60X37 CM**

### WORKING TIME

**±10H**

### RELOAD TIME

**± 4,5H**

## ENGINE

### ENGINE REFERENCE

 **MCH MOTORS**  
**BLDC «HIGH TORQUE» SERVOMOTOR**

### ENGINE TYPE

**ELECTRIC**  
**WITH OVERLOAD PROTECTION**  
**POWER (HP/KW) : 2/1,5**  
**LITHIUM BATTERY : 48V 80AH**

### GEARBOX

**6 FW / 2 BW**

### STARTING SYSTEM AND TECHNOLOGY

**ELECTRIC**  
**S3 (SOFT START AND STOP FUNCTION)**

ALLOWS YOU A SMOOTH ACCELERATION AND STOP AND AVOIDS BUMPS.

## CAPACITY

### MAX PAYLOAD (FLAT/SLOPE)

**500 KG / 350 KG**

### MAX GREADABILITY

**35%**

### NET WEIGHT

**N/A**

## ADDITIONAL INFO.

### OVERALL DIMENSIONS

**196X66X110 CM**

### TIPPER DIMENSIONS

**87X54X26,5 CM**

### TIPPING SYSTEM

**MANUAL WITH GAS PISTON**

### RUBBER TRACK SIZE

**180X60X42 CM**

### WORKING TIME

**± 8H**

### RELOAD TIME

**± 5H**



**MCH**



# M500He

## ENGINE

ENGINE REFERENCE

 **MCH MOTORS**

**BLDC «HIGH TORQUE» SERVOMOTOR**

ENGINE TYPE

**MOTEUR ÉLECTRIQUE**

AVEC PROTECTION ANTI SURCHARGE

**POWER (HP/KW) : 2/1,5**

**LITHIUM BATTERIE : 48V 80AH**

GEARBOX

**6 FW / 2 BW**

STARTING SYSTEM AND TECHNOLOGY

**ELECTRIC**

**S3 (SOFT START AND STOP FUNCTION)**

ALLOWS YOU A SMOOTH ACCELERATION AND STOP AND AVOIDS BUMPS.

## CAPACITY

MAX PAYLOAD (FLAT/SLOPE)

**500 KG / 350 KG**

MAX GREADABILITY

**35%**

NET WEIGHT

**N/A**

## ADDITIONAL INFO.

OVERALL DIMENSIONS

**196X66X110 CM**

TIPPER DIMENSIONS

**87X54X26,5 CM**

TIPPING SYSTEM

**GAS PISTON / AUTOMATIC**

RUBBER TRACK SIZE

**180X60X42 CM**

WORKING TIME

**± 8H**

RELOAD TIME

**± 5H**





# W SERIE

## W350, SIMPLE, RELIABLE AND MULTITASKING.

The first model of the MCH wheel range. The W350e will be the versatile assistant you expect. Transport up to 300kg of cargo thanks to its reliable and powerful electric motor. Equipped with 4 inflatable wheels, this machine can adapt to uneven terrain. Its 2 rear moveable wheels facilitate maneuvers in tight spaces. Unlike the machines that rely on rubber track to move, they have wheels that allow you to respect the surrounding green spaces. Solid, its use is centered on the ease and comfort of the user. The W350e is handy, easy to maneuver and to take in hand. Activate the start command and its electric motor will instantly put all of its power at your service.

Available in 2 versions, choose the dump machine most suited to your activities:

- The agriculture model with its large drop side tray for transporting bulky objects.
- The construction model and its deep bucket, perfect for transporting rubble, sand, cement ...

The W350e is a 100% electric machine. It is quieter than thermal models and more respectful of your working environment since it avoids direct polluting emissions. Its electric motor requires very little maintenance. Its lithium battery gives it an autonomy of 4 hours at full charge and an extremely short recharge time of 3.5 hours. It has a LED headlight to increase your safety so that you can better appreciate the terrain and its obstacles. It also has a USB port to which you can connect your accessories or your smartphone.

# W 350

Upcoming models :

# W 500

# W 150















# W350e

## AGRICULTURE

### ENGINE

ENGINE

**CC SERVOMOTOR**

ENGINE TYPE

**ELECTRIC  
WITH OVERLOAD PROTECTION****POWER (HP/KW) : 0,82/0,6****BATTERY : 48V 50AH****LITHIUM**

FORWARD - BAKWARD SPEED

**0,5 - 4,46 KM/H | 0.6-2.3 KM/H**

TIPPING SYSTEM

**MANUAL**

### CAPACITY

MAX PAYLOAD (FLAT/SLOPE)

**350 KG / 200KG**

MAX GREADABILITY

**30% (FULL LOAD)**

NET WEIGHT

**160 KG**

### ADDITIONAL INFO.

OVERALL DIMENSIONS

**155,5X86X101 CM**

TIPPER DIMENSIONS

**102X38,1X80 CM**

TIPPING SYSTEM

**MANUAL WITH GAS PISTON**

WHEELS (FRONT / REAR)

**16X6,50-8" / 13X5,00-6"**

WORKING TIME / RELOAD TIME

**± 10H / ± 3,5H**

# W350e

## CONSTRUCTION

### ENGINE

ENGINE

**CC SERVOMOTOR**

ENGINE TYPE

**ELECTRIC  
WITH OVERLOAD PROTECTION****POWER (HP/KW) : 0,82/0,6****BATTERY : 48V 50AH****LITHIUM**

FORWARD - BAKWARD SPEED

**0,5 - 4,46 KM/H | 0.6-2.3 KM/H**

TIPPING SYSTEM

**MANUAL**

### CAPACITY

MAX PAYLOAD (FLAT/SLOPE)

**350 KG / 200KG**

MAX GREADABILITY

**30% (FULL LOAD)**

NET WEIGHT

**160 KG**

### ADDITIONAL INFO.

OVERALL DIMENSIONS

**155,5X86X101 CM**

TIPPER DIMENSIONS

**115X38,6X 80/56 CM**

TIPPING SYSTEM

**MANUAL WITH GAS PISTON**

WHEELS (FRONT / REAR)

**16X6,50-8" / 13X5,00-6"**

WORKING TIME / RELOAD TIME

**± 10H / ± 3,5H**



# MCH

# PRICELIST

 MCH MOTORS

 HONDA

<b>M350</b>	€ 1 825	€ 2 075
<b>M350</b> e START	€ 2 075	€ 2 325
<b>M500</b>	€ 2 158	€ 2 408
<b>M500</b> e START	€ 2 408	€ 2 658
<b>M500H</b>	€ 2 492	€ 2 742
<b>M500H</b> e START	€ 2 742	€ 3 075
<b>M350e</b> ELECTRIC MOTOR	€ 4 075	
<b>M500e</b> ELECTRIC MOTOR	€ 4 325	
<b>M500He</b> ELECTRIC MOTOR	€ 4 575	
<b>W350e</b> ELECTRIC MOTOR	€ 3 742	

CUSTOMER PRICE WITHOUT VAT

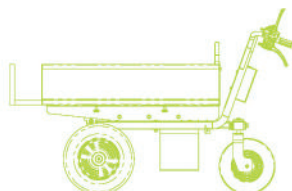
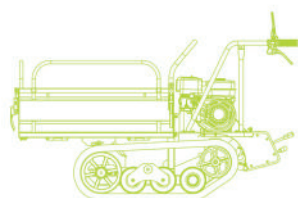





M E A



Minidumper

# HYDRO560C



		<b>KW</b>	<b>CC</b>							
GASOLINE M210		4,0	196	0,6	MANUAL START	1	1	500	350	325
GASOLINE HONDA GX 200		4,1	196	0,6	MANUAL START	1	1	500	350	325
DIESEL KM178		4,0	296	3,5	MANUAL/ELECTRIC START	1	1	500	350	360

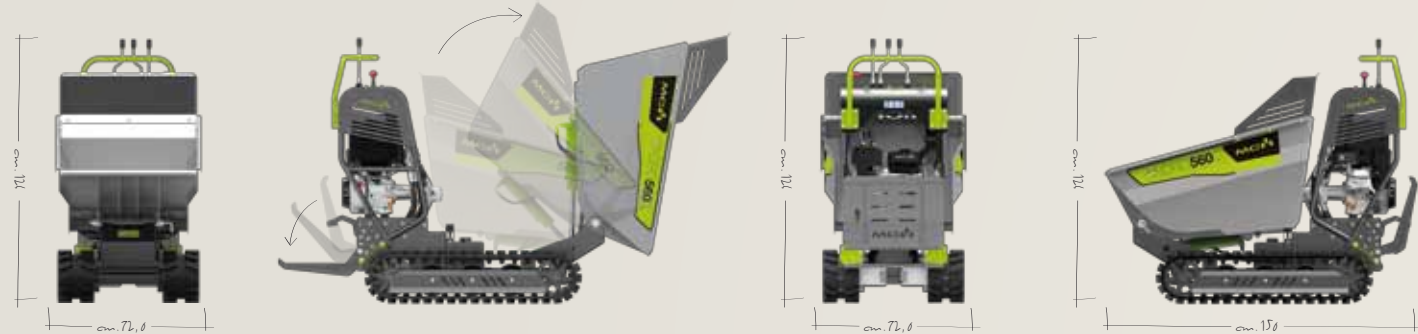

Minidumper

# HYDRO560C-S



		<b>KW</b>	<b>CC</b>							
GASOLINE M210		4,0	208	0,6	MANUAL START	1	1	500	350	385
GASOLINE HONDA GX 200		4,1	196	0,6	MANUAL START	1	1	500	350	385
DIESEL KM178		4,0	296	3,5	MANUAL/ELECTRIC START	1	1	500	350	420

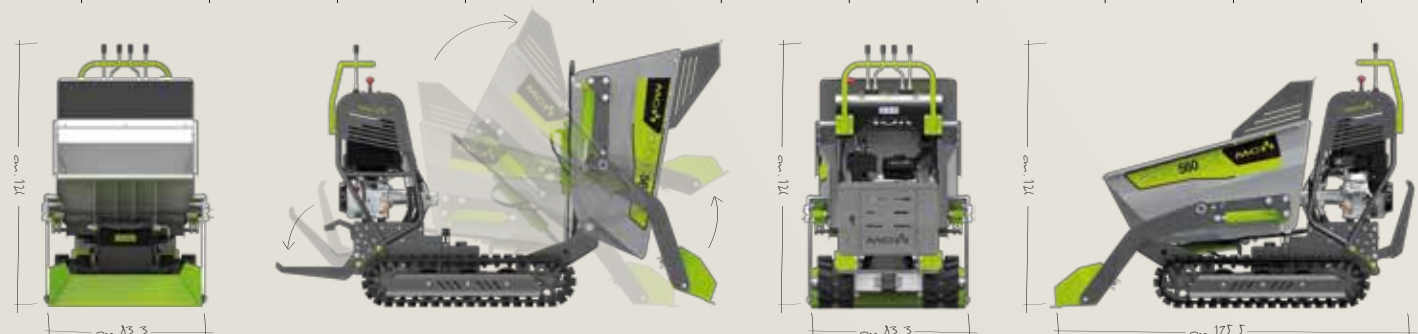

## MCH GROUP

### Our mission

roducing machines for agriculture, forestry, construction and gardening with high quality standards and innovative design for competitive and demanding global markets.

### The HYDRO560 series range

The HYDRO560 series range consists of 8 versions: HYDRO 560C - M210 BASIC/FULL; HYDRO 560C GP200 BASIC/FULL; HYDRO 560C - GX200 BASIC/FULL; HYDRO 560C - D DIESEL BASIC/FULL; HYDRO 560C BASIC (without loader); HYDRO 560C-S FULL (with loader).

### The new series of Professional Mini Dumper HYDRO 560C/CS

We have designed and produced a new series of medium-sized mini-dumpers for professional use. In them we have integrated a new concept of style with innovative technical details and modern design; Technical solutions that allow safe and easy use; High quality of materials and workmanship; Robustness and reliability beyond all expectations; Important and accurate details to facilitate their use and transport.

### WE HAVE SHAPED OUR CREATIVITY

#### Details are the essence of the product

Our products stand out for modern design and for the care of many details. From aesthetic finishes to technical contents: MS200 reinforced orbital motors; double gear hydraulic pump; double hydraulic distributor; internal and external roller protection; oil cooling radiator (optional); gasoline and diesel engines; reinforced type tracks; operator platform; reinforced frame.

#### Cured in the smallest details ...

We have decided to make the use of the machine as simple and practical as possible: high traction power, convenient platform for the operator; strong frame suitable for heavy and professional works.

**"WE WILL NOT BE THE MOST ECONOMIC IN THE MARKET BUT WE CAN SAY TO BE AT THE TOP OF QUALITY"**

*We have made every effort to create a product beyond your expectations.*

### CUSTOMER SERVICE, OUR STRENGTH...

ne of our main target on which we focus all our efforts is the care of our customers. We dedicate our daily activities to the promotion of our products until the complete satisfaction of our customer and end users of our machines. Our products are CE certified and guaranteed for 24 months from sale to the final consumer. We have all the necessary technical documentation and all the spare parts that the machines are made of.



**MCH GROUP SRL**  
 Contrada Piana - Zona Industriale  
 IT-86019 Vinchiaturo (CB) Italy

www.mchworld.com

## Minidumper series



www.mchworld.com





## Minidumper series

# HYDRO

**MCH**®



TANDEM GEAR PUMP  
PUMP FLOW  
HYDRAULIC MOTORS  
HYDRAULIC MOTORS DISPLACEMENT

BREVINI - MARZOCCHI  
3.2cc+3.2cc /RPM  
TIPO ORBITALE VERSIONE "S" (M+S)  
200cc



**FL560 Fork Lift** for Mini Dumper Series HYDRO560 PRO (with loader)  
Lifting capacity with empty machine Kg 80. Lifting height 25 cm approx.



**WB560 Speciale Wood Box** for Mini Dumpers HYDRO560 Series (series without loader)  
Hydraulic tipping, strong structure of notched base to stop the logs, easy drainage from the front door. Load capacity up to 500 Kg



**SB560 Snow Blade** for Mini Dumper Series HYDRO560 PRO (with loader).  
Working width 120 cm, height 42 cm. Manual side adjustment.



**E560 Upper Dumper Body Extensions** for HYDRO560 Series (without loader). The extension of the side of about 20 cm allows the dumper body to increase the load volume for the transport needs of bulky and not particularly heavy materials.







**MCH**

