



A light, compact, high speed 1800W coring motor, specially designed for fast wet drilling of small diameter holes up to 50mm. Ideal for chemical anchors and similar applications.

DM2 | WET DIAMOND CORE DRILL MOTOR
10201-002-211-1017-001-026



OPTIONAL ACCESSORIES: _____



AS200

0299-0132-00000-056



Sharpening plate

305-00372-000-001

DEALER

	MODEL
	DM2
Power Input	1800 Watt
Voltage	220 - 240 Volt
Frequency	50-60 Hz
No Load / Rated Load Speed, min ⁻¹	6500 / 4225
Capacity-Wet	50mm(2")
Spindle Thread	1/2" BSP Female
Soft Start & Overload Protection	With
Mechanical Safety Clutch	With
Protection Class	Class I with PRCD / GFCI
Dimensions (LxWxH) (mm)	360 x 90 x 280
Neck Diameter	60mm
Net Weight	4,5kg (9,9 Lbs)
Cable length	3,5m



A light, compact, high efficiency 1800W coring motor for convenient wet drilling up to 132mm.

DM5 | DIAMOND CORE DRILL MOTOR
10201-005-211-6062-003-026



Sharpening plate
305-00372-000-001

AS200
0299-0132-00000-056



Bit Extensions
1 1/4" x 200
305-00373-000-001
1 1/4" x 300
305-00373-000-002
1/2" BSP X 200
305-00373-000-003
1/2" BSP X 300
305-00373-000-004



Related Product:
Vacuum Cleaner DS25L
305-00371-000-001



	MODEL
	DM5
Power Input	1800W
Voltage	220-240W
Frequency	50-60Hz
Rated Load Speeds min -1	Speed 1: 780
	Speed 2: 1400
Capacity-Wet	132mm (5 1/4")
Spindle Thread	1 1/4" UNC male & 1/2" BSP female
Neck Diameter	60mm
Protection Class	Class I with PRCD / GFCI
Dimension (LxWxH) (mm)	450 x 105 x 280
Net Weight	4,8kg (10,56 Lbs)
Cable Length	3m

DEALER



A light, high efficiency 1800W, 2 speed motor for dry drilling up to 182mm.

DM52D | DIAMOND CORE DRILL MOTOR

with soft grip

10201-005-211-6062-018-100

with standard grip

10201-005-211-6062-017-100



	MODEL
	DM52D
Power Input	1800W
Voltage	220-240W
Frequency	50-60Hz
Rated Load Speeds min -1	Speed 1: 1080
	Speed 2: 2160
Percussion Frequency	Speed 1: 29 000bpm
	Speed 2: 56 000bpm
Capacity Dry	182mm(7 1/4")
Spindle Thread	1 1/4" UNC male & 1/2" BSP female
Protection Class	Class II
Dimensions(LxWxH)(mm)	505 x 105 x 210
Net Weight	5,0kg (11,0 Lbs)
Cable length	3m

DM52D | DIAMOND CORE DRILL MOTOR

with soft grip

10201-005-211-6062-018-100

with standard grip

10201-005-211-6062-017-100

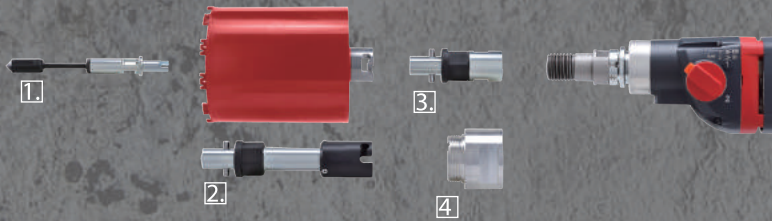

ADD quick release dry drilling equipment

- 1. Centering pilot, ADD
0202-0111-00000-009
- 2. Extension 200m
0299-0114-00000-005
- 3. ADD quick release
0299-0114-00000-004
- 4. 1 1/4" to ADD M42 Adaptor
301-03022-000-003

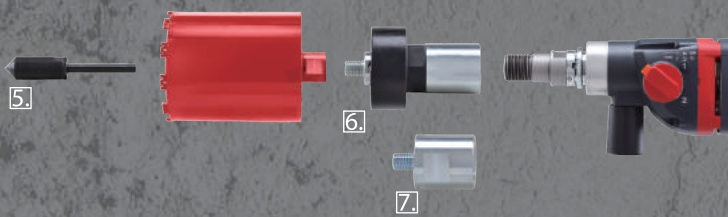

M16 dry drilling equipment

- 5. Centering Pilot
0202-0111-00000-008
- 6. M16 dust extractor
0299-0114-00000-003
- 7. M16 Adaptor
302-04311-903-010

Related Products



AS200
0299-0132-00000-056



Vacuum Cleaner DS25L
305-00371-000-001



Sharpening plate
305-00372-000-001

AGP®

DEALER



Heavy duty 3 speed 2000W drilling machines with magnesium construction for drilling up to 162mm.



DM6P | DIAMOND CORE DRILL MOTOR

Wet - 1 1/4" & 1/2" Spindle
10201-006-211-6062-001-026

Wet - 1/2" Female Spindle only
10201-006-211-1017-001-026



	MODEL	
	DM6P	DMC6P
Power Input	2000 Watt	
Voltage	200 Volt	
Frequency	50-60 Hz	
Loaded Speeds	560 / 910 / 2560	
Capacity-Wet Rig-Mounted:	162mm	
Capacity-Wet Hand-Held:	82mm	
Capacity-Dry	n/a	182mm
Spindle Thread	1 1/4" & 1/2" BSP	
Neck Diameter	60mm	
Protection Class	Class I + PRCD	
Dimensions(LxWxH)	437 X 115 X 289	
Net Weight	6,3 kg (13,9 Lbs)	6,4 kg (14,1 Lbs)
Cable Length	3,5m	

DM6P & DMC6P



Related Product:
Vacuum Cleaner DS25L
305-00371-000-001



Sharpening plate
305-00372-000-001



AS200
0299-0132-00000-056



- Bit Extensions
- 1 1/4" x 200
305-00373-000-001
 - 1 1/4" x 300
305-00373-000-002
 - 1/2" BSP X 200
305-00373-000-003
 - 1/2" BSP X 300
305-00373-000-004



Water Collector Set
(includes 3 membranes)
0299-0249-0004-001

Replacement membranes
(5 pack)
0299-0250-0004-001

Vacuum plate:
Fits AS200, S350 & S500
0299-0143-00000-007



Vacuum
hose



Vacuum Pump
VP140



VP140
Vacuum Tank

10713-000-222-0000-010-004 0299-0110-00000-002

DMC6P

Wet + Dry Version

10201-006-211-6062-002-026

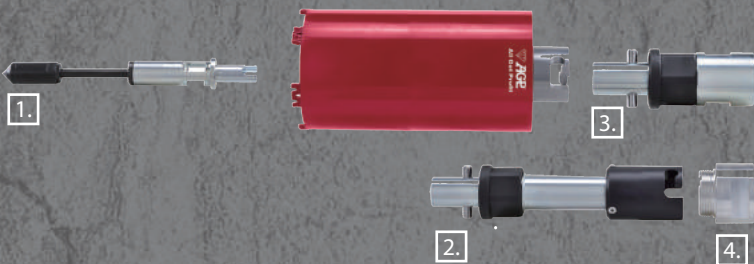

ADD quick release dry drilling equipment

- 1. Centering pilot, ADD
0202-0111-00000-009
- 2. Extension 200mm
0299-0114-00000-005
- 3. ADD quick release
0299-0114-00000-004
- 4. 1 1/4" to ADD M42 Adaptor
301-03022-000-003



M16 dry drilling equipment

- 5. Centering Pilot
0202-0111-00000-008
- 6. M16 dust extractor
0299-0114-00000-003
- 7. M16 Adaptor
302-04311-903-010

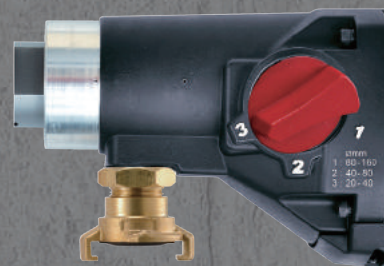

Vacuum Adaptor Head



Water Feed Adaptor Head



DEALER

AGE[®]

A specially designed heavy-duty 2 speed 2000W motor for dry drilling of reinforced concrete up to 162mm, and standard dry drilling up to 262mm.

DM62 | DRY DIAMOND CORE DRILL MOTOR

10201-006-211-6062-003-026



Built in vertical level



LED Indicator for optimizing drilling efficiency with overload and overheat warning

Magnesium alloy motor housing for minimal weight and maximum strength

Horizontal level for precision

Soft grip handle for maximum comfort

Handle in line with spindle for precise control

Switchable soft percussion for optimized dry drilling

	MODEL
	DM62
Power Input	2000 Watt
Voltage	220 - 240V
Frequency	50-60Hz
Rated Load Speeds min ⁻¹	Speed 1: 750
	Speed 2: 1140
Percussion Frequency	Speed 1: 20 000 bpm
	Speed 2: 30 400 bpm
Capacity-Dry (Reinforced Concrete)	162mm (6 1/4")
Capacity-Dry (Brick)	262mm (10 5/16")
Spindle Thread	1 1/4" UNC male & 1/2" BSP female
Protection Class	Class II
Dimensions(LxWxH)	430 x 122 x 290 mm
Net Weight	6,2kg (13,64 Lbs)
Cable length	3m

DM62 | DRY DIAMOND CORE DRILL MOTOR

10201-006-211-6062-003-026

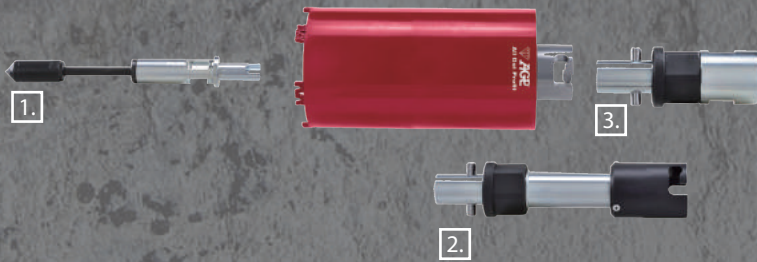

ADD quick release dry drilling equipment

- 1. Centering pilot, ADD
0202-0111-00000-009
- 2. Extension 200mm
0299-0114-00000-005
- 3. ADD quick release
0299-0114-00000-004



M16 dry drilling equipment

- 4. Centering pilot
0202-0111-00000-008
- 5. M16 dust extractor
0299-0114-00000-003
- 6. M16 Adaptor
302-04311-903-010

Related Products



AS200
0299-0132-00000-056



Vacuum Cleaner DS25L
305-00371-000-001



Sharpening plate
305-00372-000-001

AGP®

DEALER



Heavy duty 3 speed 2500W drilling machines with magnesium construction for drilling up to 202mm.

DM8P DIAMOND CORE DRILL MOTOR
10201-008-211-6062-001-026

Handle inline with spindle for precise control

Magnesium alloy motor housing and gear case for minimal weight and maximum strength

Soft grip handle for maximum comfort

Load indicator light for optimizing drilling efficiency with overload and overheat warning



Built-in vertical level

3 speed oil bath gearbox with clutch

Motor features constant speed electronics, maintaining even speed for stable drilling and longer core bit life

Water Supply Kit

OPTIONAL ACCESSORIES



Bit Extensions

1 1/4" x 200

305-00373-0003-001

1 1/4" x 300

305-00373-0003-002

1/2" BSP x 200

305-00373-0003-003

1/2" BSP x 300

305-00373-0003-004



AS200

0299-0132-00000-056



Sharpening plate

305-00372-000-001

DEALER

MODEL

DM8P

Power Input	2500 Watt
Voltage	220 - 240 Volt
Frequency	50-60 Hz
Rated Load Speeds min ⁻¹ R	480 / 1050 / 2200
Capacity - Wet	Hand-Held: 82mm (3")
	Rig-Mounted: 220mm (8")
Spindle Thread	1 1/4" UNC male
	1/2" BSP female
Neck Diameter	60mm
Protection Class	Class I with PRCD / GFCI
Dimensions(LxWxH) (mm)	463 x 127 x 310
Net Weight	7,3kg (16Lbs)
Cable length	3,5m



DM9 / 10 / 12
DM14

Aluminum housing for better cooling and durability

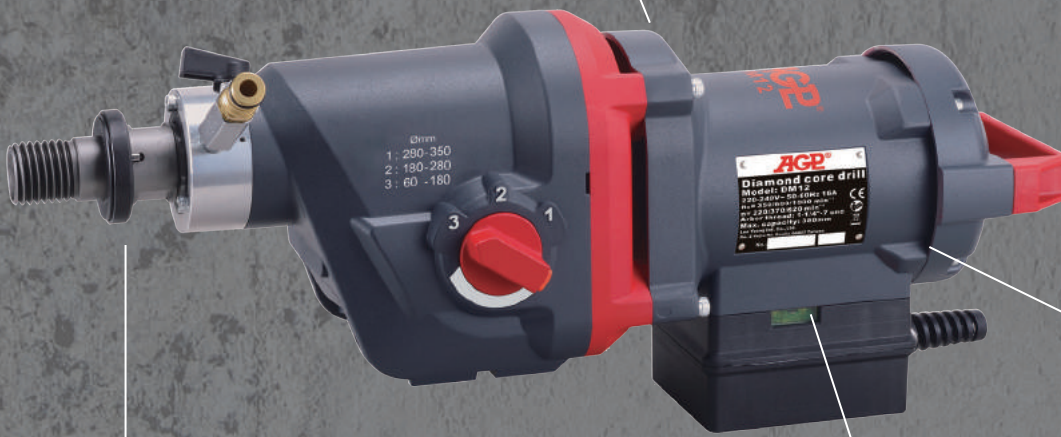

DIAMOND CORE DRILL MOTORS

- DM9
10201-009-225-2023-001-026
- DM10
10201-010-225-2023-001-026
- DM12
10201-012-225-2023-001-026
- DM14
10201-014-206-2023-001-026

Slow Start - A unique automatic hole starting function which protects core bits from breakage

Built in Tubular Spirit Level for precision

Anti-Seize Ring prevents core bits from getting stuck on the spindle

Aluminum housing for better cooling and durability



Mounted To The Optional Rigs:



DM14 | DIAMOND CORE DRILL MOTOR

10201-014-206-2023-001-026

	MODEL			
	DM9	DM10	DM12	DM14
Power Input	3500 Watt			
Voltage	220-240V			
Frequency	50-60Hz			
Rated Load Speeds min ⁻¹	345 / 630 / 1000	270 / 480 / 780	220 / 370 / 620	225 / 300 / 565 / 780
Drilling Capacity	Ø250mm (10")	Ø300mm (12")	Ø350mm (14")	Ø400mm (16")
Gear Oil Type	W90			
Gear Oil Capacity	625ml			
Spindle Thread	1 1/4" UNC male & 1/2" BSP female			
Protection Class	Class I With PRCD / GFCI			
Soft Start & Overload Protection	With			
Dimensions(LxWxH) (mm)	550 x 155 x 210			
Weight	12,9kg (28,4 Lbs)			13,5kg (29,7 Lbs)
Cable length	3,5m			



Built in vertical level

230V Models



110V Models



Indicator Light for optimizing drilling efficiency with overload and overheat warning

DIAMOND CORE DRILL MOTOR Optional Accessory



S350

0299-0132-00000-058



S500

0299-0132-00000-046



Bit Extensions

1 1/4" x 200
305-00373-000-001

1 1/4" x 300
305-00373-000-002

1/2" BSPx 200
305-00373-000-003

1/2" BSPx 300
305-00373-000-004

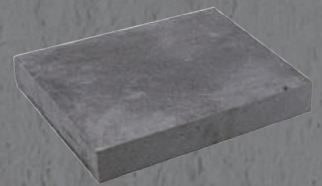

Sharpening plate
305-00372-000-001

To provide clearance for the switch box when mounting the motor to some models of other manufacturers' rigs. (The spacer also adds an extra 80mm to the maximum core bit diameter with a given stand.)

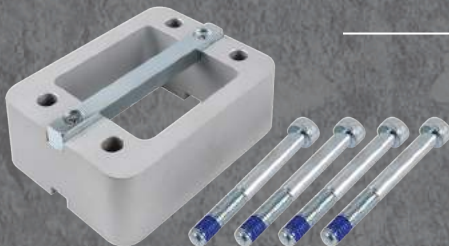
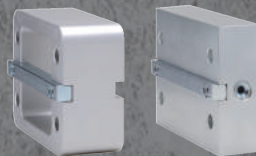

40mm Spacer Kit
0299-0214-0000-001



Diamond Core Drilling Accessories

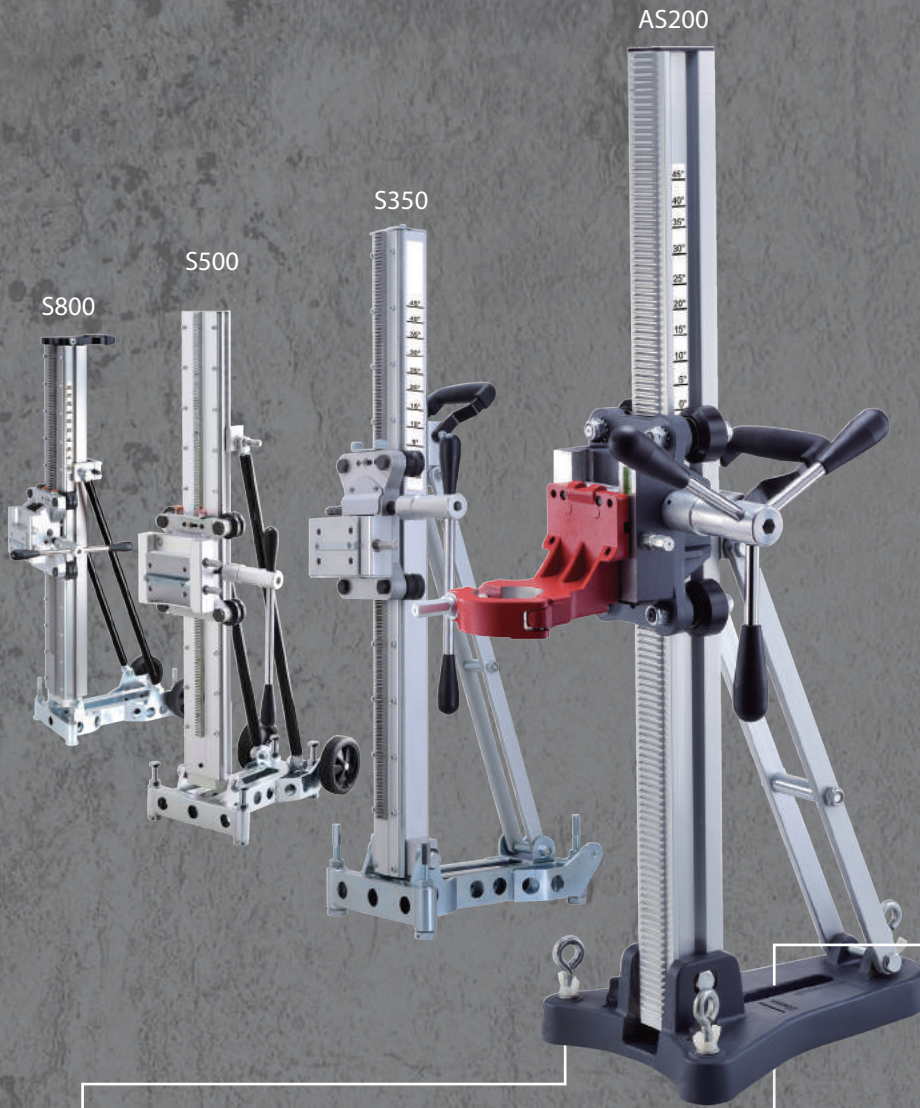

Water Collector Set
(includes 3 membranes)
0299-0249-0004-001

Replacement membranes
(5 pack)
0299-0250-0004-001



Anchoring Plate
For S350, S500 & S800
302-04464-903-001

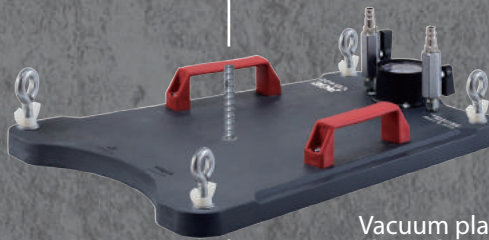

Vacuum plate:
Fits AS200, S350 & S500
0299-0143-0000-007



Related Product:
Vacuum Cleaner DS25L
305-00371-000-001



Vacuum Pump
VP140
10713-000-222-0000-010-004



VP140
Vacuum Tank
0299-0110-0000-002

Related Motors



DM6P

Wet - 1 1/4" & 1/2" Spindle

10201-006-211-6062-001-026

Wet - 1/2" Female Spindle only

10201-006-211-1017-001-026



DM62

10201-006-211-6062-003-026

DMC6P

Wet + Dry Version

10201-006-211-6062-002-026



DM5

10201-005-211-6062-003-026



DM52D

10201-005-211-6062-001-026



Model	AS200	S350	S500	S800
Capacity w/o extension spacers (mm)	Ø202	Ø352	Ø350	Ø350
Max. Capacity with extension spacers (mm)	N/A	N/A	Ø500	Ø800
Effective Stroke (mm)	500	660	690	760
Dimensions (LxWxH) (mm)	361 x 250 x 890	435 X 245 X 984	548 X 240 X 1025	555 x 275 x 1035
Net Weight (not Including crank handle)	10.5kg (23,1 Lbs)	16,6kg (36,5 Lbs)	19,1kg (42,0 Lbs)	26,5kg (58,4 Lbs)



DEALER



Wet or dry tile core drill specially designed for core drilling either blind or through holes in tiles, ceramics, porcelain, stone, concrete, masonry, glass and similar materials.

TC402 | TILE CORE DRILL
10101-040-200-3060-001-026



■ **Suction Centering Guide (Standard)**

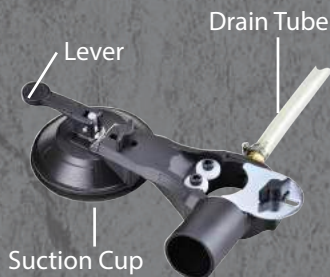

■ **Water Supply Kit (Standard)**

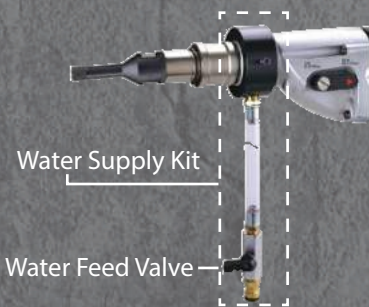

DEALER

	MODEL
	TC402
Power Input	620W
Voltage	220-240V~ 50/60Hz or 110-120V~ 50/60Hz
No Load / Rated Load min ⁻¹	
Speed 1	4500 / 2700
Speed 2	7500 / 4500
Capacity	40mm (1 9/16")
Adapter Thread	G 1/2" BSP, M14-2,0
Protection Class	Class II with PRCD / GFCI
Neck Diameter	43mm
Dimensions	348mm x 100mm x 300mm
Net WeightWeight	2,5kg (5,51 Lbs)



Compact and high endurance concrete grinders with excellent dust control.

G5 | CONCRETE GRINDER

10204-005-207-4049-009-100



Constant speed electronics for an even finish

Anti-vibration mountings for maximum operator comfort

SM7 | CONCRETE GRINDER

10204-007-207-4042-001-026



Anti-vibration mountings for maximum operator comfort

Constant speed electronics for an even finish

Bristles for efficient dust containment

	MODEL	
	G5	SM7
Power Input	2200 Watt	
Voltage	220-240 Volt	
Frequency	50-60Hz	
No Load/min-1	4500-9500	3200-6500
Wheel Diameter	125mm (5")	180mm (7")
Arbor	22,23mm (7/8") 25,4 (1")(Double-Sided)	22,23mm (7/8")
Dimensions (LxWxH)(mm)	246 x 280 x 325	
Weight	5,75kg (12,65 Lbs)	5,74kg (12,62 Lbs)
Cable length	3m	

G5 | CONCRETE GRINDER

10204-005-207-4049-009-100

Variable speed for different applications



Tool free rotating cover for edge grinding

OPTIONAL ACCESSORIES:



Floor Grinding Trolley



Related Products
Vacuum Cleaner DS25L
[305-00371-000-001](#)



Related Product:
Vacuum Cleaner DS35M
[305-00371-000-002](#)

SM7 | CONCRETE GRINDER

10204-007-207-4042-001-026

Variable speed for different applications



Tool free detachable cover with magnet for edge grinding

OPTIONAL ACCESSORIES:



Floor Grinding Trolley



Related Product:
Vacuum Cleaner DS25L
[305-00371-000-001](#)



Related Product:
Vacuum Cleaner DS35M
[305-00371-000-002](#)

AGP

125mm High endurance concrete grinder with excellent dust control

G125 | CONCRETE GRINDER
10204-005-207-4049-003-026



LED Indicator for optimizing grinding efficiency with overload and overheat warning

Variable speed for different applications

Adjustable ergonomic front handle allows clearance for edge grinding

Robust 2200W universal motor with constant speed grinding for creating even finishes



Tool-free sliding cover for edge grinding

Effective dust control skirt with spring suspension and replaceable brush

MODEL

G125

Power Input	2200W (220V)
Voltage, Frequency	220-240V~ 50-60Hz
No Load / min ⁻¹	4300 - 7200
Wheel Diameter	125mm (5")
Arbo	22.23mm (7/8") & 25.4 (1") (Double-Sided)
Spindle	M14 or 5/8-11 (Specify when ordering)
Dimensions (LxWxH)	500mm x 195mm x 175mm
Weight	4.7kg (10.3Lbs)

DEALER



125mm concrete grinder with super-efficient, high frequency brushless motor for long life and long duty cycles

BG5 | HIGH FREQUENCY BRUSHLESS CONCRETE GRINDER

10204-005-006-4049-002-026

2200W Brushless Permanent Magnet Synchronous Motor for outstanding power and efficiency. Constant speed is maintained regardless of load for an even finish

LED indicator for optimizing grinding efficiency with overload and overheat warning

Anti-Vibration handle mounts for fatigue free operation

Effective dust control skirt with spring suspension and replaceable brush

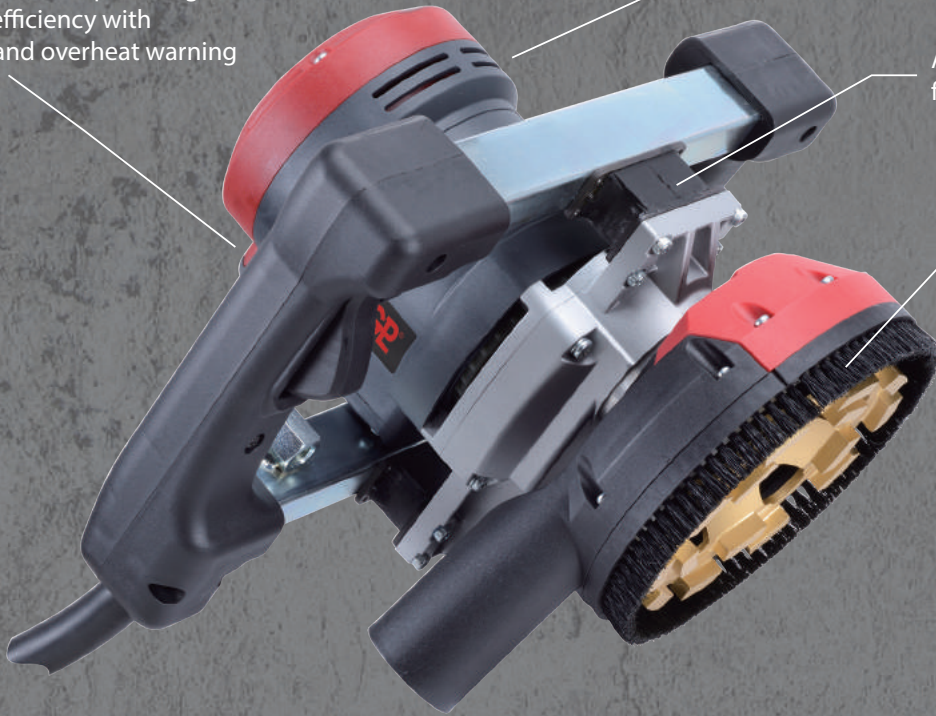

Tool-free sliding cover for edge grinding

P4K | POWER CONVERTER

10101-040-200-3060-001-026



LCD Information Display shows voltage, error codes, etc.

4500W power converter with special circuitry which allows it to accept single phase 100V to 240V and converts it to 3 phase, high frequency to control the motor

Converter can preset various speeds for different applications

Converter with built-in PRCD has full electronic protection for over and under voltage, thermal and current overload

MODEL

P4K(Power Converter)

Voltage	100V - 240V ~ 50-60Hz
Max. Power Input	1~ 4500W
Max. Power Output	3~ 4000W
Weight	3,1kg (6,9 Lbs)
Protection	IP55

MODEL

BG5(Concrete Grinder)

Power Input	3~ 2200W
No Load / min ⁻¹	3850 - 5800
Wheel Diameter	125mm (5")
Arbor	22,23mm (7/8") & 25,4 (1") (Double-Sided)
Spindle	M14 or 5/8-11 (Specify when ordering)
Dimensions (LxWxH)	235 x 290 x 235 mm
Weight	5,1kg (11,3 Lbs)
Protection	IP55

DEALER



125mm concrete grinder with super-efficient, high frequency brushless motor for long life and long duty cycles

BG125 | HIGH FREQUENCY BRUSHLESS CONCRETE GRINDER

10204-005-006-4049-001-026

LED Indicator for optimizing grinding efficiency with overload and overheat warning

Adjustable ergonomic front handle allows clearance for edge grinding

2200W Brushless Permanent Magnet Synchronous Motor for outstanding power and efficiency. Constant speed is maintained regardless of load for an even finish

Effective dust control skirt with spring suspension and replaceable brush



Tool-free sliding cover for edge grinding

P4K | POWER CONVERTER

10101-040-200-3060-001-026

LCD Information Display shows voltage, error codes, etc.



4500W power converter with special circuitry which allows it to accept single phase 100V to 240V and converts it to 3 phase, high frequency to control the motor

Converter can preset various speeds for different applications

Converter with built-in PRCD has full electronic protection for over and under voltage, thermal and current overload

MODEL

P4K(Power Converter)

Voltage	100V - 240V ~ 50-60Hz
Max. Power Input	1~ 4500W
Max. Power Output	3~ 4000W
Weight	3,1kg (6,9 Lbs)
Protection	IP55

MODEL

BG125(Concrete Grinder)

Power Input	3~ 2200W
No Load / min ⁻¹	3850 - 5800
Wheel Diameter	125mm (5")
Arbo	22,23mm (7/8") & 25,4 (1") (Double-Sided)
Spindle	M14 or 5/8-11 (Specify when ordering)
Dimensions (LxWxH)	455 x 200 x 175 mm
Weight	4,6kg (10,1 Lbs)
Protection	IP55

DEALER



A light weight and balanced sander, with pivoting sanding head and effective dust control.

GS9FE | DRYWALL SANDER
10404-009-218-2004-001-004



Standard carry bag for easy transport
308-01001-149-003

Related Product:



Vacuum Cleaner DS25L
305-00371-000-001



Vacuum Cleaner DS35M
305-00371-000-002



MODEL

GS9FE

Power Input	550 Watt
Voltage	220-240V
Frequency	50-60Hz
No Load min ⁻¹	650-1800
Full Load min ⁻¹	380-950
Sanding Disc	ø255mm (8 7/8")
Dimensions(LxWxH)(mm)	1580 x 260 x 350
Net Weight	4,7kg (10,4 Lbs)
Cable length	4,2m

DEALER



A powerful wall chaser with a maximum depth of 50 mm and cutting width up to 47 mm. Features an optional efficient guide rail system.

CG150 | WALL CHASER
10203-006-229-3042-001-026

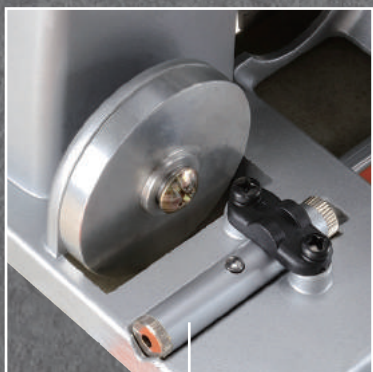
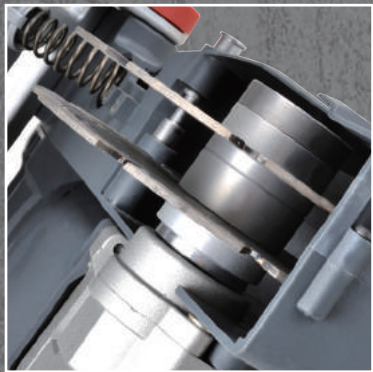

Laser Pointer



	MODEL
	CG150
Power Input	2500 Watt
Voltage	220-240V
Frequency	50-60Hz
No Load RPM	6500
Max. Blade Diameter	Ø150mm
Blade bore size	22,23mm (7/8")
Max Depth of Cut	50mm
Max Channel Width	47mm
Cut to Ceiling	25mm
Cut to Edge	28mm
Soft Start	YES
Overload Protection	YES
Thermal Protection	YES
Constant Speed	YES
Cable Length	5m
Weight (Without cable and blade)	7,2kg (15.84Lbs)

CG150 | WALL CHASER

10203-006-229-3042-001-026



LED load indicator

-  Glows green: normal load
-  Flash red: full load reached
-  Glows red: overload or overheat

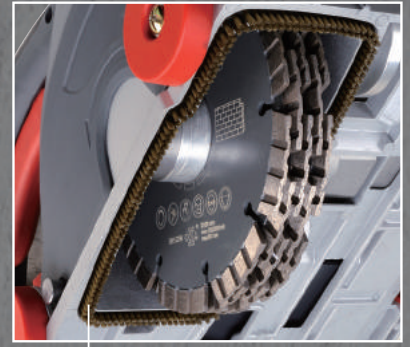

5 blades

Built in dust collection brush effectively retains dust. Includes spacers for both 2 and 5 blade chasing.

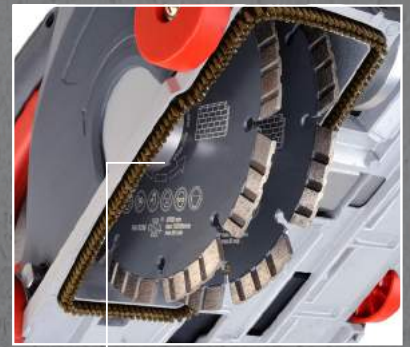

2 blades

Tool-Free Arbor Screw for fast and easy blade changes

RELATED PRODUCT:



Vacuum Cleaner DS25L
305-00371-000-001



Vacuum Cleaner DS35M
305-00371-000-002

OPTIONAL ACCESSORIES:



Universal:
150mm Diamond Saw Blade
150 x H10 x T2,6 x 22,23mm
305-00036-000-068

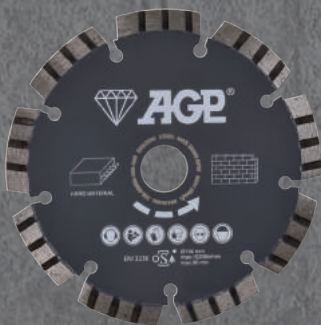

Hard Material:
150mm Diamond Saw Blade
150 x H10 x T2,6 x 22,23mm
305-00036-000-069

Optional quick set-up Guide Rail System provides maximum operator convenience and minimizes human error.



Guide rail support Set (1000mm)
0299-0246-0000-001



Guide rail 1400mm
0299-0065-00149-021



DEALER



Ideal wet and dry vacuums for multiple purpose use with automatic filter cleaning by magnetic pulse.

DS25L | Dust Class L
VACUUM CLEANER
305-00371-000-001



25 liter tank

DS35M | Dust Class M
VACUUM CLEANER
305-00371-000-002



35 liter tank

OPTIONAL ACCESSORIES:



Replacement fleece dust bags (5 pack)
0299-0026-00000-004



Accessories kit
305-00375-000-001

- |Over full indicator light
- |Variable speed for different conditions
- |Storage for accessories, hose and cable
- |Auto-start function for the connected power tool
- |Magnetic pluse automatic filter cleaning for maximum efficiency

	MODEL	
	DS25L	DS35M
Power consumption (max)	1600 Watt	
Dust Class	L	M
Volume Flow (Max) measured at the motor head	64 l/s	
Volume Flow (Max) measured at the end of hose	42 l/s	
Vacuum (max.) measured at the motor head	259 bar	
Vacuum (max.) measured at the end of hose	230 bar	
Container volume (max.) Gross-Dust-Water	25/20/15L	35/25/22 L
Sound pressure level	69,0 db (A)	
Dimensions (cm)	43 x 39 x 49	53 x 40 x 55
Weight	12,7kg	15,7kg
Power Cable Length	8,0m	
Reach	13m	

DEALER



405mm handheld wet or dry diamond saw with 3200w motor for up to 150mm depth of cut. Ideal for in-door cutting.

C16 | 405mm CONCRETE SAW
10203-016-206-4043-001-164

Magnesium blade guard provides maximum strength and minimum weight

LED Indicator
Indicates load conditions

Integrated water feed system

Tool-free detachable splash guard

Depth of cut 150mm

Tool-free detachable guide rollers for perpendicular cuts and reduced operator fatigue

	MODEL	
	C14	C16
Rated power	2800 Watt	3200 Watt (actual) 2700 Watt (certificate)
Voltage	220-240 Volt	
Frequency	50-60 Hz	
No load RPM	4500	3900
Linear speed with blade	83,6m/s (14")	82,7m/s (16")
Blade Diameter	355mm (14")	405mm (16")
Arbor	25,4mm (1")	
Max. Cutting Depth	125mm (5")	150mm (6")
Protection Class	Class I with PRCD / GFCI	Class II with PRCD / GFCI
Weight	7,9kg (17,42 Lbs)	9,6kg (21,1 Lbs)
Weight (with guide rollers)	8,3kg (18,3 Lbs)	10,1kg (22,2 Lbs)
Dimension(LxWxH)	611 x 245 x 280 (mm)	660 x 259 x 280 (mm)
Cable Length	3m	

C16 | 405mm
CONCRETE SAW
10203-016-206-4043-001-164

OPTIONAL ACCESSORIES:



Ø 405 Diamond Saw Blade(Ø25,4)
305-00036-000-063



FLUSH CUTTING
Detachable blade guard
with toggle latches for
flush cutting (WITH-
OPTIONAL FLANGE)



HY Pattern Flush Cutting Kit-1"
arbor 6-bolt (60mm bolt hole circle)
0299-0213-0000-002



Related Product:
Vacuum Cleaner DS25L
305-00371-000-001



C14 | 355mm
CONCRETE SAW
10203-014-206-4043-001-164

OPTIONAL ACCESSORIES:



Related Product:
Vacuum Cleaner DS25L
305-00371-000-001



Ø 355 Diamond Saw Blade(Ø25,4)
305-00036-000-063



Dry Dust Skid Assembly
0299-0212-0004-002



Optional Dust Skid
provides excellent
dust control for
dry cutting





450mm (18") wet concrete saw with 6500W high frequency permanent magnet synchronous motor for up to 175mm depth of cut. Flush cut capability.

C18 | CONCRETE SAW

10203-018-006-4043-001-001

Blade Guard with Toggle Latches for quick conversion to Flush cutting

LED Indicator Indicates load conditions

Special Motor Coupling Cable



6500W, water cooled permanent magnet motor for outstanding power and efficiency Constant speed is maintained regardless of load

Guide Rollers for stability and perpendicular cutting

Rim Brush for flush cutting (optional)

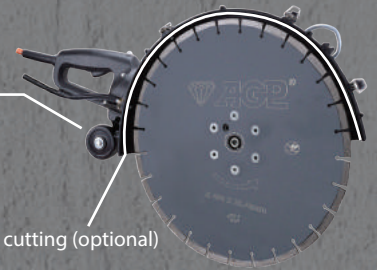

P8K | Power Converter

10700-000-010-0000-001-026

Converter Build-in PRCD has full electronic protection for over and under voltage, thermal and current overload supplies high frequency current to the tool



LCD Information Display shows voltage, elapsed hours, error codes, etc.

3 phase power supply cable



Adaptor for single phase supply included

Water cooled 8000W power converter with special circuitry which allows it to accept **3 phase 380V**, **3 phase 230V** and **single phase 230V** supply at the maximum possible power level

MODEL

C18 (Concrete Saw)

MODEL

P8K (Power Converter)

Power: Input (Maximum)

$^3\varnothing\sim 380-480V$: 16A 8000W

$^3\varnothing\sim 220-240V$: 25A 7000W

$^1\varnothing\sim 200-240V$: 32A 7000W

Min. Water Flow (25°C) 3,5 L/min (1 gpm)

Max. Water Pressure 7 bar (100 psi)

Dimensions (L x W x H) 460 x 220 x 260 mm

Weight 7,3kg (16,06 Lbs)

Power	
$^3\varnothing\sim 380-480V$	6500W
$^3\varnothing\sim 220-240V$	5500W (25A), 3500W (16A)
$^1\varnothing\sim 200-240V$	5500W (32A), 3500W (16A)
*No Load RPM	2500/min
Linear Speed w/18" blade	59,8m/s
Blade Diameter	457mm (18")
Arbor	25,4mm (1")
Max. Cutting Depth	175mm (6-7/8")
Dimensions (L x W x H)	810 x 260 x 310 mm
Weight	11,6kg (25,5 Lbs)

DEALER



330mm (13") wet ring saw with 3200W universal motor for up to 220mm depth of cut.

R13 | RING SAW

10203-013-206-1001-001-026

PATENTED

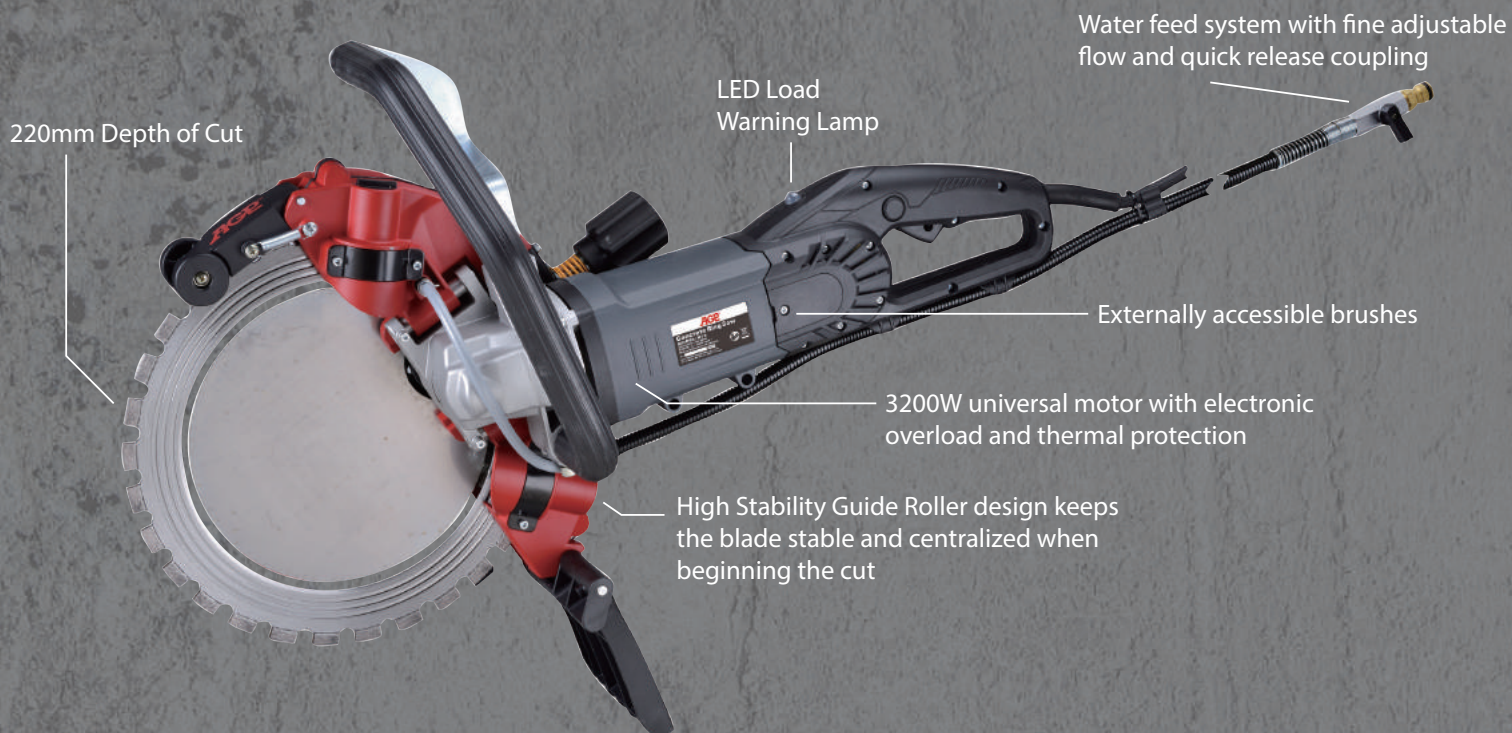

Patented One Step Drive Tensioner is fast and easy to adjust and keeps tension equalized



Blade changes can be performed quickly and require no disassembly of the cover

DEALER

	MODEL
	R13
Power Input	220V: 3200W
Voltage	220-240V~ 50/60Hz
No Load /min ⁻¹	2850
Linear Speed	49,2 m/s
Blade Diameter	330mm (13")
Max. Depth of Cut	220mm (8,7")
Protection Class	Class I (220V models with PRCD / GFCI)
Dimensions (incl. blade)	730 x 280 x 450mm
Weight	12,6kg (27,7 Lbs) (not incl. blade)



400mm (16") wet ring saw with 6500W high frequency permanent magnet synchronous motor for up to 300mm depth of cut.

R16 | RING SAW

10203-016-006-1001-001-001

PATENTED

300mm Depth of Cut

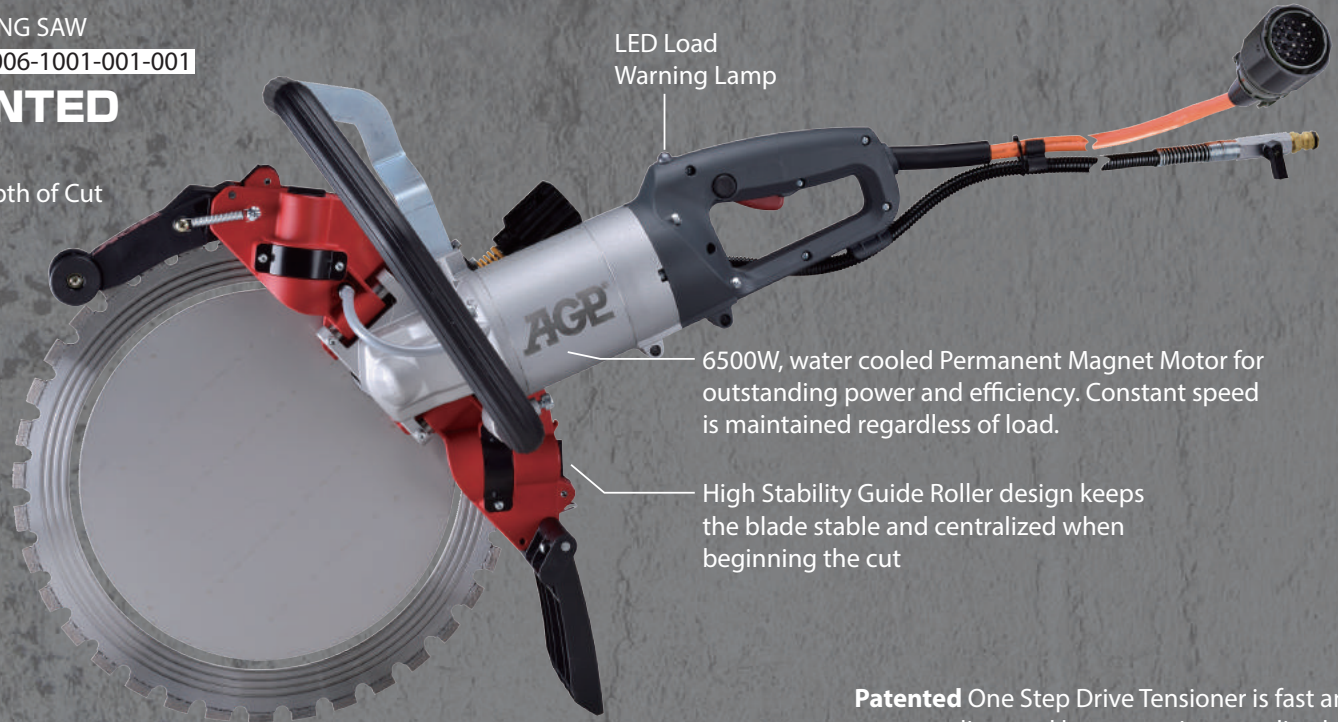

LED Load Warning Lamp

6500W, water cooled Permanent Magnet Motor for outstanding power and efficiency. Constant speed is maintained regardless of load.

High Stability Guide Roller design keeps the blade stable and centralized when beginning the cut

P8K | Power Converter

10700-000-010-0000-001-026

Converter Build-in PRCD has full electronic protection for over and under voltage, thermal and current overload supplies high frequency current to the tool



LCD Information Display shows voltage, elapsed hours, error codes, etc.

3 phase power supply cable

Water cooled 8000W power converter with special circuitry which allows it to accept **3 phase 380V, 3 phase 230V** and **single phase 230V** supply at the maximum possible power level

Patented One Step Drive Tensioner is fast and easy to adjust and keeps tension equalized



Easy to adjust guide rollers



Adaptor for single phase supply included

Blade changes can be performed quickly and require no disassembly of the cover

MODEL

P8K (Power Converter)

Power: Input (Maximum)	
³ Ø~380-480V : 16A	8000W
³ Ø~220-240V : 25A	7000W
¹ Ø~200-240V : 32A	7000W
Min. Water Flow (25°C)	3,5 L/min (1 gpm)
Max. Water Pressure	7 bar (100 psi)
Dimensions (L x W x H)	460mm x 220mm x 260mm
Weight	7,3kg (16,06 Lbs)

MODEL

R16 (Ring Saw)

Power	
³ Ø~380-480V	6500W
³ Ø~220-240V	3600W (16A), 5500W(25A)
¹ Ø~200-240V	3600W (16A), 5500W(32A)
*No Load RPM	2500/min
Linear Speed	53,0m/s
Blade Diameter	400mm (15-3/4")
Max. Cutting Depth	300mm (11-13/16")
Dimensions (L x W x H)	830mm x 240mm x 460mm
Weight	12,8kg (27,5 Lbs)

DEALER

AGP

SCS7 | STONE CUTTING
CIRCULAR SAW
10203-007-201-4042-010-100

The 1800W, 180mm wet stone saw. A Perfect solution for fast, precise wet cutting of all kinds of stone and masonry materials up to 55mm thick.

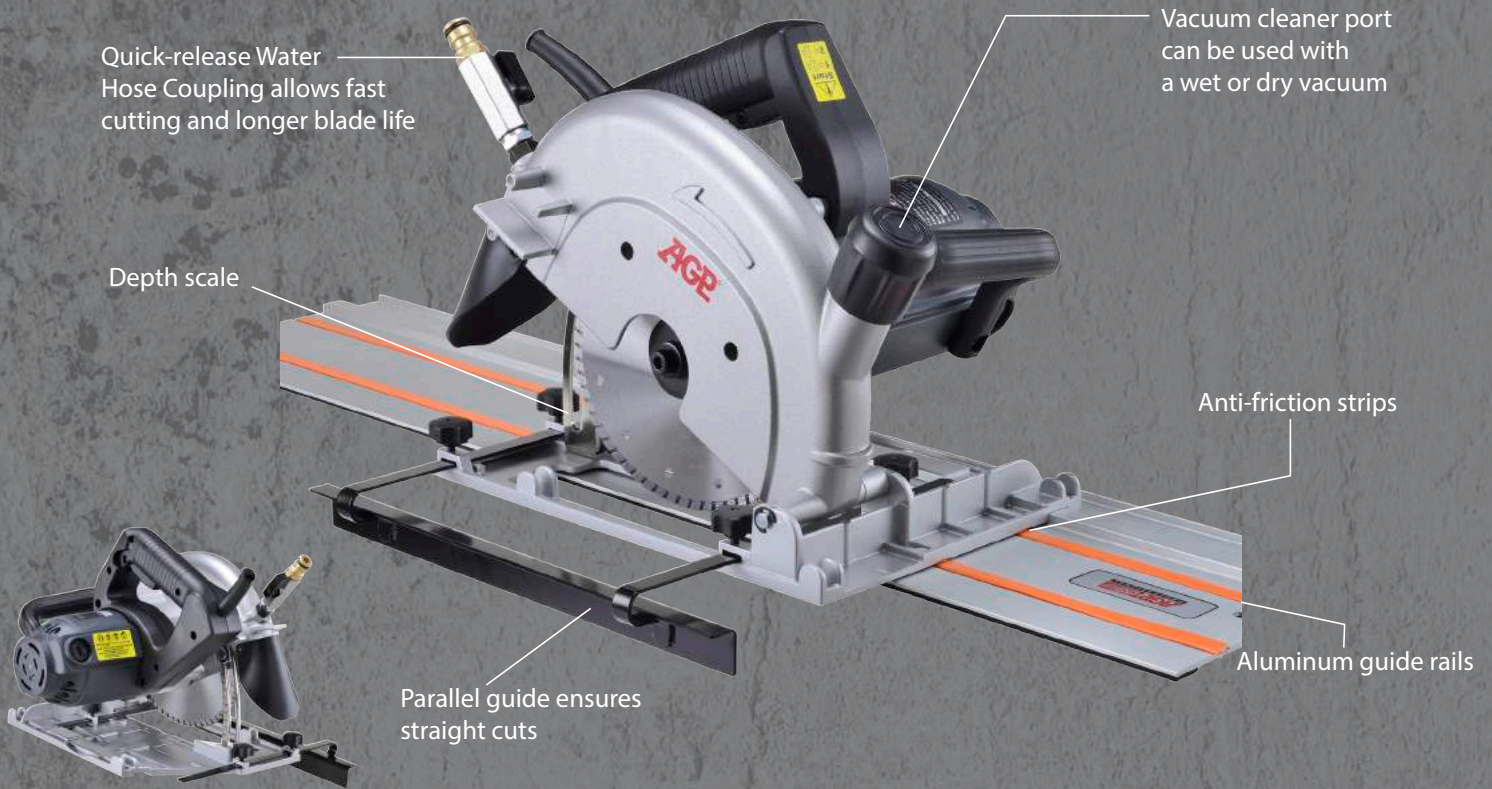

OPTIONAL ACCESSORIES:



The guide rail allows perfectly straightcuts and the cut-to-fit rubber strip shows the operator exactly where the cutting line will be.

■ Aluminum Guide Rails

Guide Rail
Guide Rail

Spec.

174mm x 1400mm
174mm x 800mm

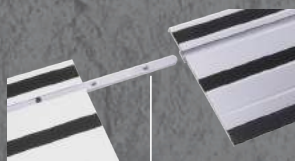

Guide Rail Connector
0299-0106-0000-001



Lever Clamp
305-00179-000-001

DEALER

MODEL	
SCS7	
Power Input	1800W
Voltage	220-240V~ 50/60Hz
No Load min ⁻¹	5800
Arbor	22.23 mm (7/8")
Max. Blade Diameter	180 mm
Max. Cutting Depth	55mm
Overload Protection	With
Protection Class	Class I with PRCD / GFCI
Dimensions (L x W x H)	350mm x 270mm x 265mm
Net Weight	6.7 kg (14.74 Lbs)